

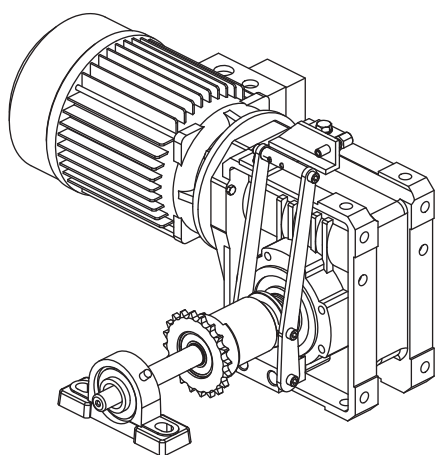

FIBO 300 LB - 1,5 HP

FIBO 400 LB - 3,0 HP



FIBO 300 LB - 1,5 HP

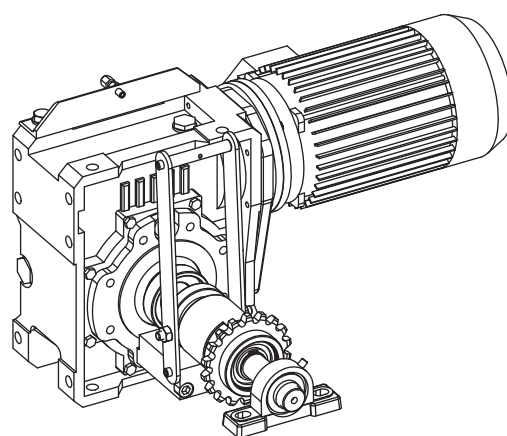

FIBO 400 LB - 3,0 HP

Electro-mechanical geared motor for heavy industrial sliding gates

- Worm-crown gear inner coupling in an oil bath entirely supported by ball bearings
- Chain drive
- Three-phase power supply

GENERAL WARNINGS FOR PEOPLE SAFETY

THANK YOU

Thank you for purchasing a Fadini product. Please read these instructions carefully before using this appliance. The instructions contain important information which will help you get the best out of the appliance and ensure safe and proper installation, use and maintenance. Keep this manual in a convenient place so that you can always refer to it for the safe and proper use of the appliance.

INTRODUCTION

This operator is designed for a specific scope of applications as indicated in this manual, including safety, control and signaling accessories as minimum required with Fadini equipment. □ Any applications not explicitly included in this manual may cause operation problems or damages to properties and people. □ Meccanica Fadini S.r.l. is not liable for damages caused by the incorrect use of the equipment, or for applications not included in this manual or for malfunctioning resulting from the use of materials or accessories not recommended by the manufacturer. □ The manufacturer reserves the right to make changes to its products without prior notice. □ All that is not explicitly indicated in this manual is to be considered not allowed.

BEFORE INSTALLATION

Before commencing operator installation assess the suitability of the access, its general condition and the structure. □ Make sure that there is no risk of impact, crushing, shearing, conveying, cutting, entangling and lifting situations, which may prejudice people safety. □ Do not install near any source of heat and avoid contacts with flammable substances. □ Keep all the accessories able to turn on the operator (transmitters, proximity readers, key-switches, etc) out of the reach of the children. □ Transit through the access only with stationary operator. □ Do not allow children and/or people to stand in the proximity of a working operator. □ To ensure safety in the whole movement area of a gate it is advisable to install photocells, sensitive edges, magnetic loops and detectors. □ Use yellow-black strips or proper signals to identify dangerous spots. □ Before cleaning and maintenance operations, disconnect the appliance from the mains by switching off the master switch. □ If removing the actuator, do not cut the electric wires, but disconnect them from the terminal box by loosening the screws inside the junction box.

INSTALLATION

All installation operations must be performed by a qualified technician, in observance of the Machinery Directive 2006/42/CE and safety regulations EN 12453 - EN 12445. □ Verify the presence of a thermal-magnetic circuit breaker 0,03 A - 230 V - 50/60 Hz upstream the installation. □ Use appropriate objects to test the correct functionality of the safety accessories, such as photocells, sensitive edges, etc. □ Carry out a risk analysis by means of appropriate instruments measuring the crushing and impact force of the main opening and closing edge in compliance with EN 12445. □ Identify the appropriate solution necessary to eliminate and reduce such risks.

□ In case where the gate to automate is equipped with a pedestrian entrance, it is appropriate to prepare the system in such a way to prohibit the operation of the engine when the pedestrian entrance is used. □ Apply safety nameplates with CE marking on the gate warning about the presence of an automated installation. □ The installer must inform and instruct the end user about the proper use of the system by releasing him a technical dossier, including: layout and components of the installation, risk analysis, verification of safety accessories, verification of impact forces and reporting of residual risks.

INFORMATION FOR END-USERS

The end-user is required to read carefully and to receive information concerning only the operation of the installation so that he becomes himself responsible for the correct use of it. □ The end-user shall establish a written maintenance contract with the installer/maintenance technician (on -call). □ Any maintenance operation must be done by qualified technicians. □ Keep these instructions carefully.

WARNINGS FOR THE CORRECT OPERATION OF THE INSTALLATION

For optimum performance of system over time according to safety regulations, it is necessary to perform proper maintenance and monitoring of the entire installation: the automation, the electronic equipment and the cables connected to these. □ The entire installation must be carried out by qualified technical personnel, filling in the Maintenance Manual indicated in the Safety Regulation Book (to be requested or downloaded from the site www.fadini.net/supporto/downloads). □ Operator: maintenance inspection at least every 6 months, while for the electronic equipment and safety systems an inspection at least once every month is required. □ The manufacturer, Meccanica Fadini S.r.l., is not responsible for non-observance of good installation practice and incorrect maintenance of the installation.

DISPOSAL OF MATERIALS

Dispose properly of the packaging materials such as cardboard, nylon, polystyrene etc. through specializing companies (after verification of the regulations in force at the place of installation in the field of waste disposal). Disposal of electrical and electronic materials: to remove and dispose through specializing companies, as per Directive 2012/19/UE. Disposal of substances hazardous for the environment is prohibited.



CE DECLARATION OF CONFORMITY of the manufacturer:

Meccanica Fadini S.r.l. (Via Mantova, 177/A - 37053 Cerea - VR - Italy) declares under own responsibility that: **Fibo 300 LB - Fibo 400 LB** comply with the 2006/42/CE Machinery Directive, and also that they are sold to be installed in an "automatic system", along with original accessories and components as indicated by the manufacturing company. An automatic gate operator is, by law, a "machinery" and therefore the installer must fit the equipment with all of the applicable safety norms. The installer is also required to issue the installer's Declaration of Conformity. The manufacturer is not liable for possible incorrect use of the product. The product complies with the following specific norms: analysis of the risks and subsequent action to cure them as per EN 12445 and EN 12453, Low Voltage Directive 2014/35/UE, Electromagnetic Compatibility 2014/30/UE. In order to certify the product, the manufacturer declares under own responsibility the compliance with the EN 13241-1 PRODUCT NORMS.

Meccanica Fadini S.r.l.
Director in charge

INSTRUCTIONS FOR THE INSTALLATION OF THE GEARED MOTORS FIBO 300 LB - FIBO 400 LB ON SLIDING GATES.

FOR A PERFECT APPLICATION AND IN ORDER TO ACHIEVE A RELIABLE PERFORMANCE OF FIBO 300 LB - FIBO 400 LB IT IS RECOMMENDED THAT THE FOLLOWING STEPS BE CARRIED OUT AND DRAWINGS BE KEPT TO.

FIBO 300 LB - FIBO 400 LB are a geared motors for heavy sliding gates driven by a chain; it is available in 1,1 kW (1,5 HP three-phase) and 2,2 kW (3,0 HP three-phase) versions.

FIBO 300 LB - FIBO 400 LB are a versatile motor-powered units and can suit the most various applications on industrial sliding gates mounted on a track and made up of a single panel or of hinged multiple panels driven together to one side by a metal chain (not supplied with the equipment, it must be suitable to the power required to electrically operate the gate).

They are a strong and reliable automatic systems, fitted with a manually adjustable clutch system, and a worm-gear coupling made of bronze and steel, supported by ball bearings. A manual override device allows for the gate to be operated by hand in case of a power failure or disconnection.

GATE INSPECTION

Make sure that the gate sliding track be firmly set into the ground foundation to prevent it from moving or setting at a later stage, which might eventually lead into the gate going off the rail during its opening/closing travels.

NOTE WELL:



- make sure that proper gate stops be fixed to ground in open and closed gate positions, to prevent the gate from overrunning the upper track;
- make sure the gate be fitted with a safety system to prevent it from falling over;
- prevent the gate from crashing into the gate posts or gate stops.

INSTALLING WITH THE CHAIN STRETCHER

Firmly screw the geared motor on a bracket or a proper support to be fitted to the installation. Fixing holes are provided in the unit to this purpose as in Pic. 1: the position of the geared motor is to take into account the fixing of the shaft ball bearing support. The **chain stretcher** is to be positioned on the side opposite that where the geared motor is installed, considering a sufficient distance for the chain to be properly kept stretched and slacking prevented.

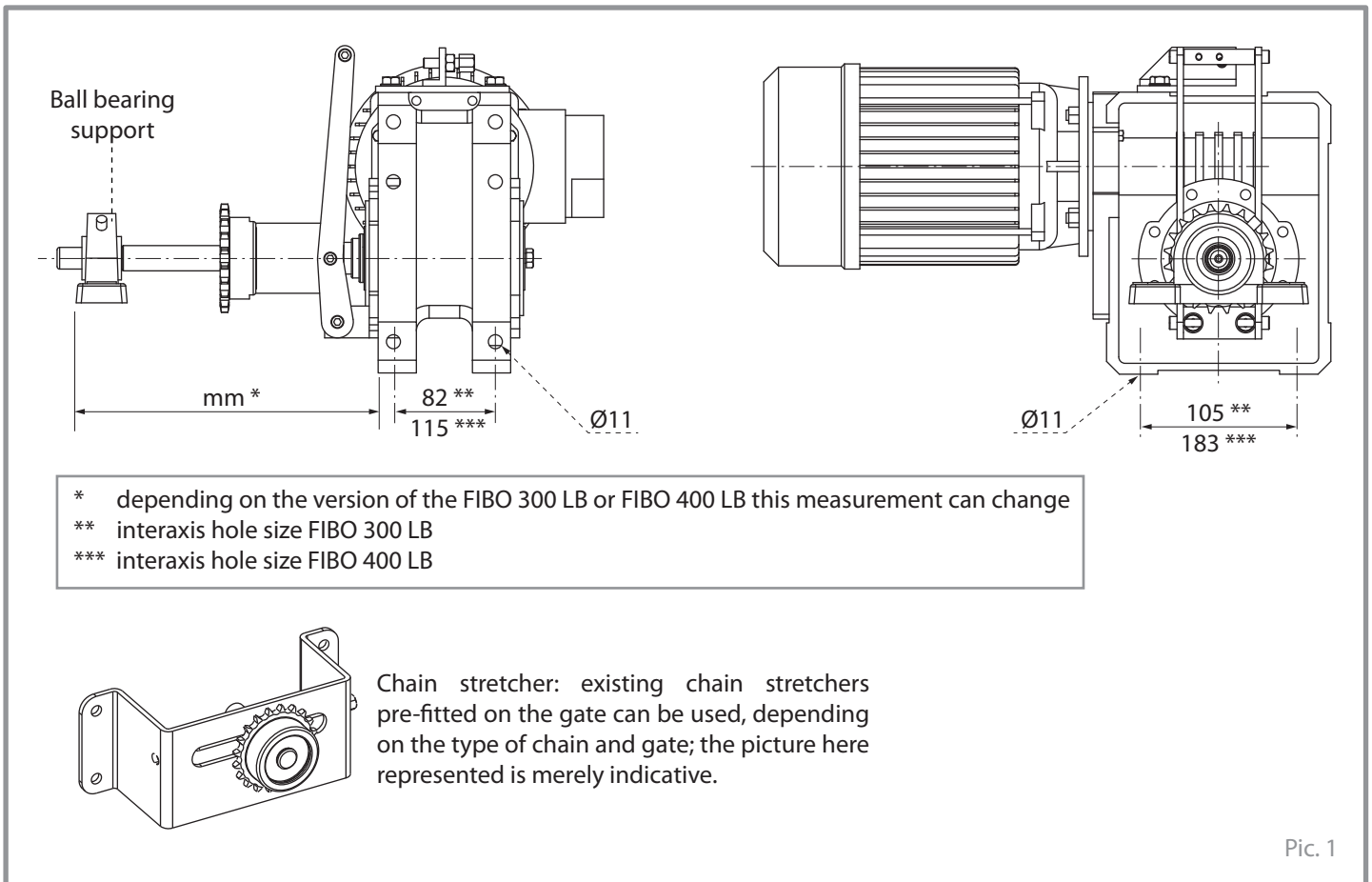

FIXING THE GATE TO THE CHAIN

To properly fix the gate to the chain, consider a clearance of 10-15 cm between the fixing point and the center lines of the geared motor and chain stretcher respectively, once the gate has reached the ends of the permitted travel (Pic. 2).

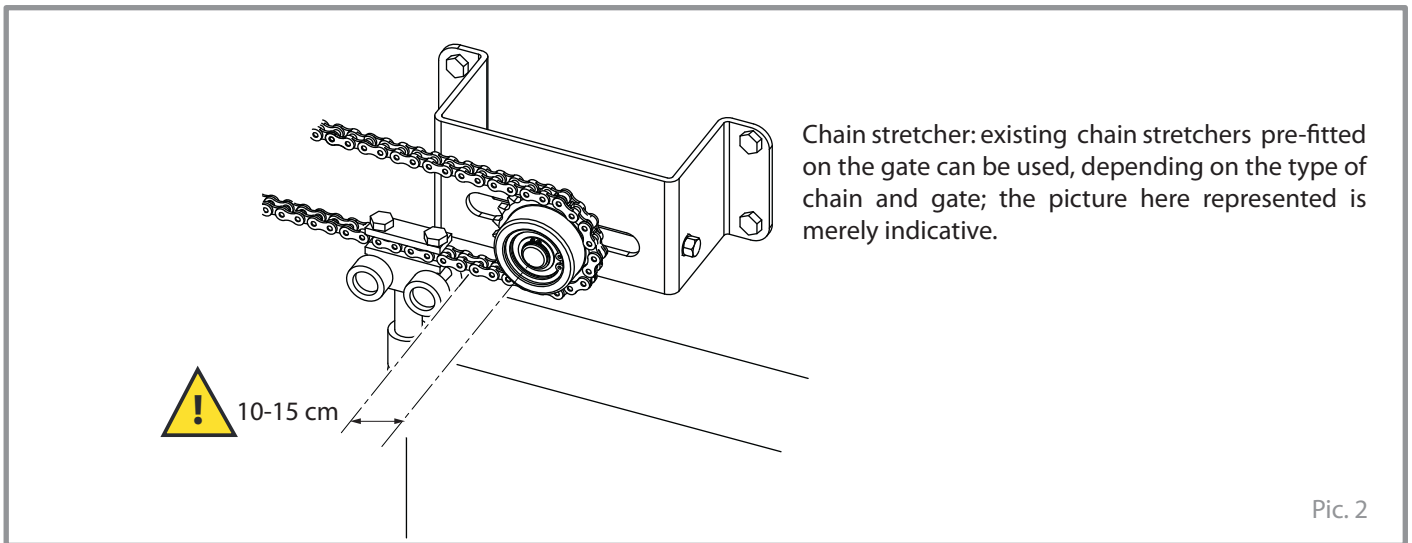

OVERRIDE FOR MANUAL OPERATION

In order to disconnect the gate from the FIBO 300 LB - FIBO 400 LB geared motors, in situations where power failure is occurring or during the installation phases, it is required that the override handle be operated. This can be carried out even at a distance from the motor by means of a metal rope operated by a release lever (Pic. 3).

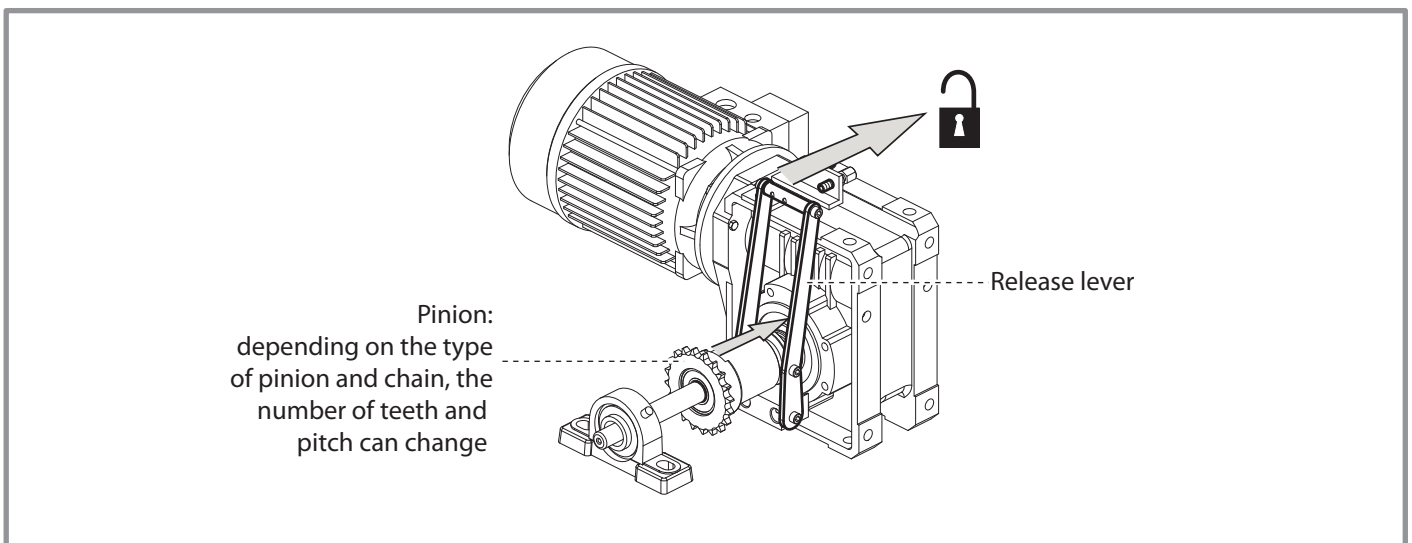

INSTALLING THE LIMIT SWITCHES

The limit switches are to be installed in such a way that the striking plate (also fitted to the chain) can activate the switches without problems. The electrical connections must comply with the instructions of the Elpro electronic controller (Pic. 4).

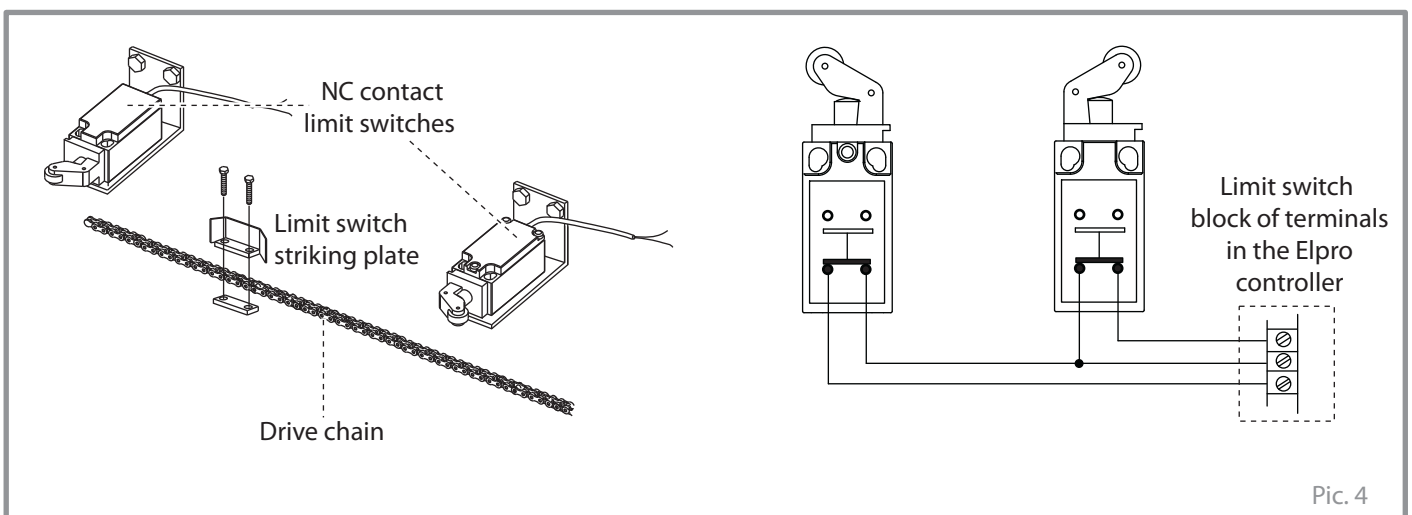

GENERAL LAYOUT OF THE INSTALLATION

For installations where large gates are involved, pre-existing accessories can be found, specifically dedicated to the type of gate to be operated. Therefore the installation diagram of the components as represented below is to be considered only indicative, and cannot be limited to the accessories here included.

General layout for guidance: it is the installer's responsibility to lay the conduits for the electrical connections in a proper and correct way.

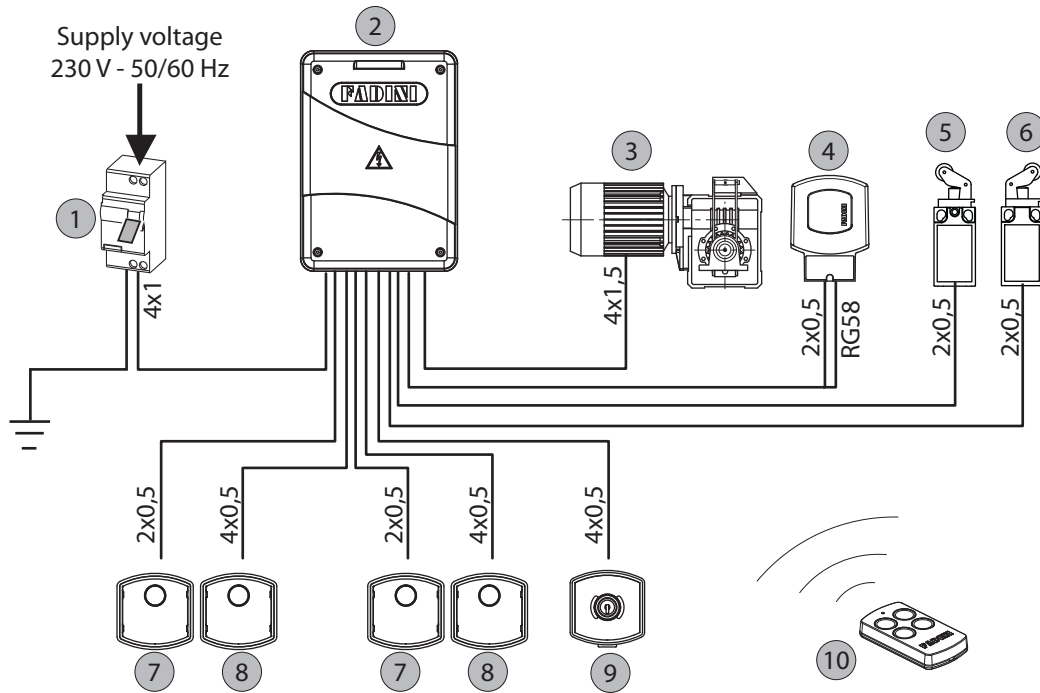

NOTE WELL: the entire electrical equipment is to be properly connected to ground.

- 1 - 230 V - 50/60 Hz, 0,03 A, magneto-thermal differential circuit breaker (not included)
- 2 - Control board with power contactors and plug-in radio receiver card
- 3 - Three-phase FIBO 300 LB or FIBO 400 LB geared motor
- 4 - Flasher
- 5 - Opening external limit switch
- 6 - Closing external limit switch
- 7 - Photocell transmitter
- 8 - Photocell receiver
- 9 - Key-switch
- 10 - Transmitter

Types of cables to be used:

For power supply to motors, safety and command accessories: FROR CEI 20-20 CEI EN 50267-2-1

For the aerial: RG58 (included, 3 m)

NOTE: for distances beyond 50 m increase the cable square section to suit the real absorption requirements of the devices as indicated in the CEI EN 60204-1 norms.

Pic. 5

MOTOR CONNECTIONS

English

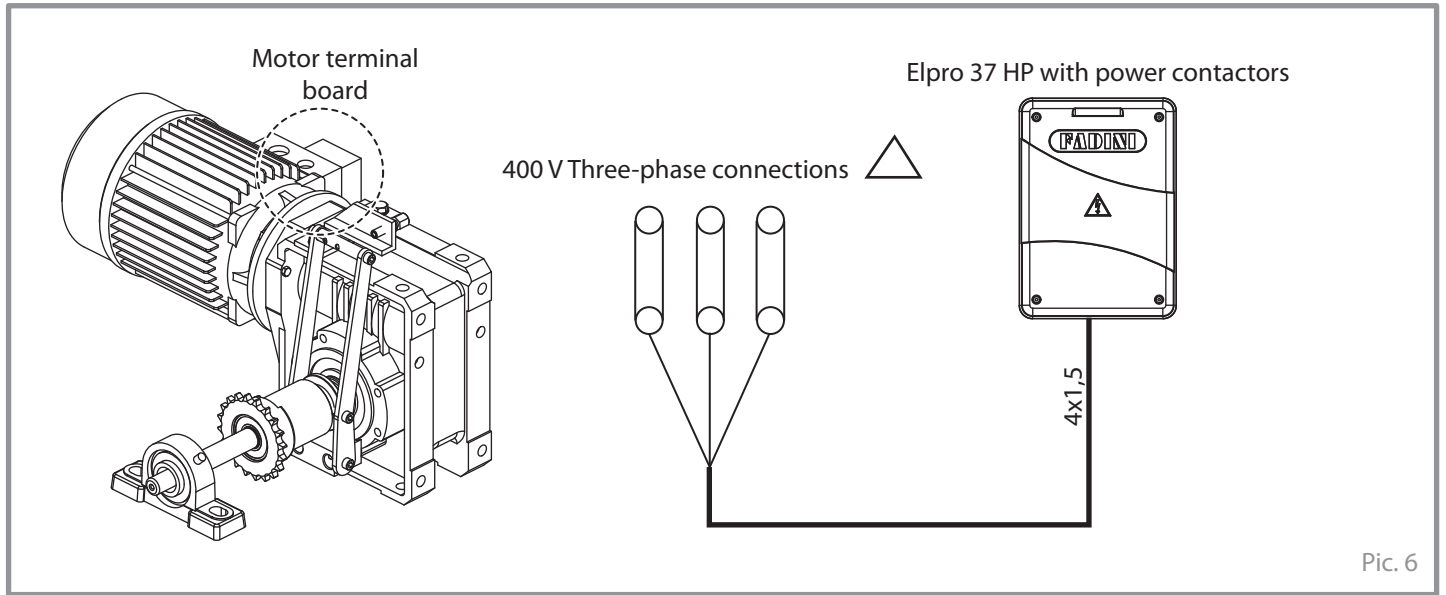

Pic. 6

FIBO 300 LB TECHNICAL DATA

ELECTRIC MOTORS

Power output	1,1 kW (1,5 HP)
Absorbed power	1.500 W
Three-phase supply voltage	230/400 Vac
Frequency	50/60 Hz
Absorbed current	5,1/3 A
Motor rotation speed	1.400 rpm (50 Hz) - 1.700 rpm (60 Hz)
Intermittent service	S3 - 75%
Cooling	by fan

ELECTRO-MECHANICAL GEARED OPERATOR

Ratio	1:40
Output revolutions	35 rpm (50 Hz) - 42,5 rpm (60 Hz)
Drive gear	Z 20 - 1/2"
Nominal torque	300 Nm (50 Hz) - 247 Nm (60 Hz)
Transfer speed (1.400 rpm - 50 Hz)	9 m/1'
Transfer speed (1.700 rpm - 60 Hz)	11 m/1'
Hydraulic oil type	Oil Fadini - art. 706L
Working temperature	-25 °C +80 °C
Fibo 300 LB weight	28 kg
Protection standard	IP 55

PERFORMANCE

Service cycle	25 s opening - 30 s dwell - 25 s closing - 30 s dwell
Complete cycle time	110 s
Complete opening - dwell - closing - dwell cycles	No. 33/hour
Annual cycles (with 8 hours of use per day)	No. 96.000

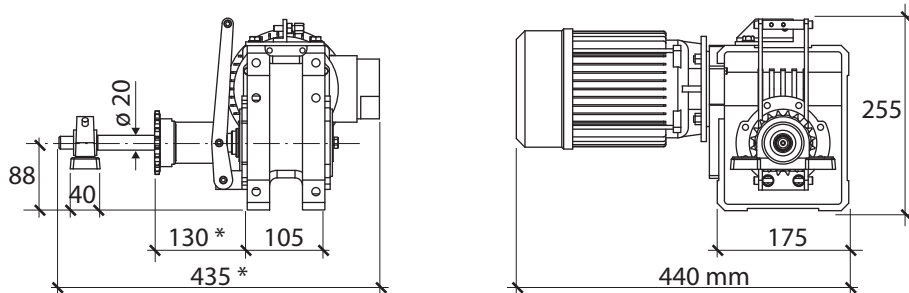
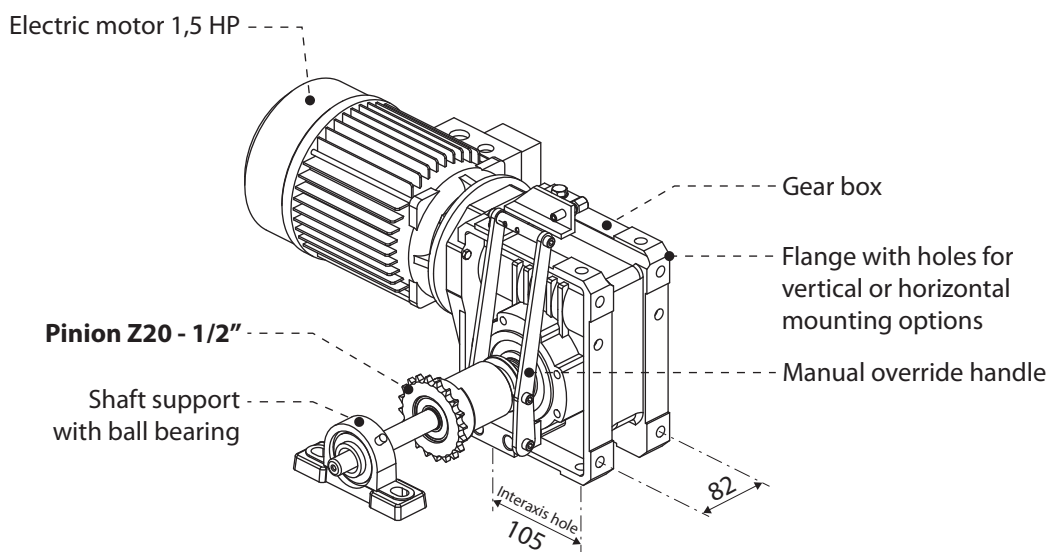

* depending on the version of the FIBO 300 LB this measurement can change

FIBO 400 LB TECHNICAL DATA

ELECTRIC MOTORS

Power output	2,2 kW (3,0 HP)
Absorbed power	2.800 W
Three-phase supply voltage	230/400 Vac
Frequency	50/60 Hz
Absorbed current	9,4/5,4 A
Motor rotation speed	1.400 rpm (50 Hz) - 1.700 rpm (60 Hz)
Intermittent service	S3 - 40%
Cooling	by fan

ELECTRO-MECHANICAL GEARED OPERATOR

Ratio	1:56
Output revolutions	25 rpm (50 Hz) - 30,3 rpm (60 Hz)
Drive gear	Z 18 - 3/4"
Nominal torque	840 Nm (50 Hz) - 700 Nm (60 Hz)
Transfer speed (1.400 rpm - 50 Hz)	9 m/1'
Transfer speed (1.700 rpm - 60 Hz)	11 m/1'
Hydraulic oil type	Oil Fadini - art. 706L
Working temperature	-25 °C +80 °C
Fibo 400 LB weight	52 kg
Protection standard	IP 55

PERFORMANCE

Service cycle	25 s opening - 30 s dwell - 25 s closing - 30 s dwell
Complete cycle time	110 s
Complete opening - dwell - closing - dwell cycles	No. 33/hour
Annual cycles (with 8 hours of use per day)	No. 96.000

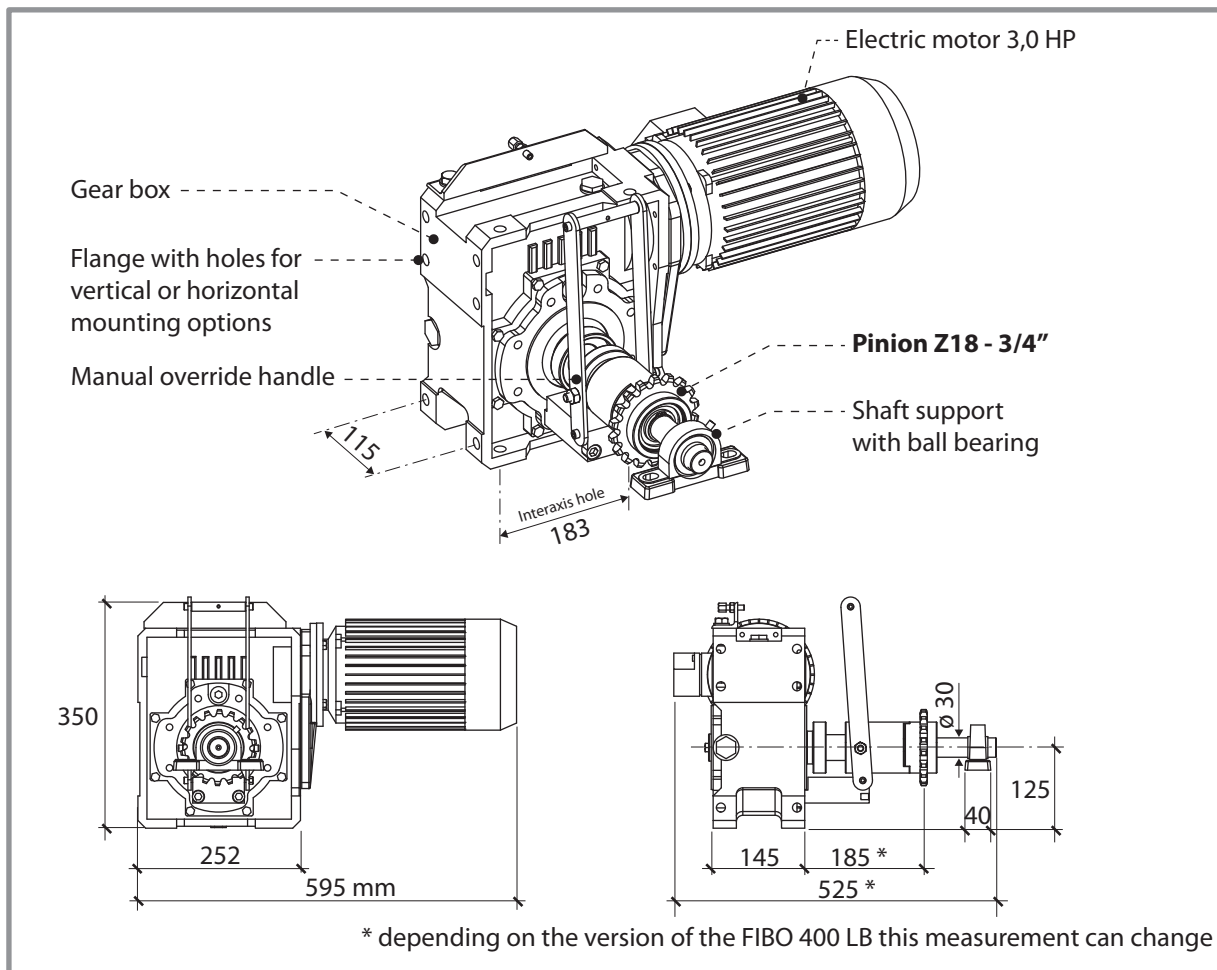

English